

Owners & Safety Manual

UC-9 CRIMPING JAW HOUSING



The UC-9 is designed to crimp wire connectors. Optional insert dies are needed for crimping



Power Pack must have 25-S Cam for use with UC-9 Jaw and Housing. 25-S pictured to left.

Simonds
Manufacturer of Pneumatic and Hydraulic Tools



Wear Eye Protection

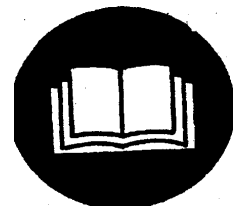

Read manual carefully.

248 ELM ST.
SOUTHBRIDGE, MASSACHUSETTS 01550
USA
PHONE: 508-764-3235
FAX: 508-765-5125
E-mail: sales@simonds-inc.com

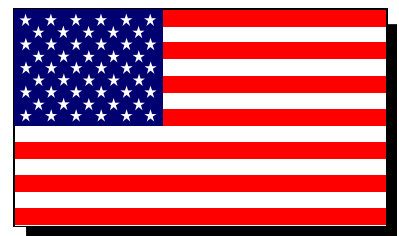

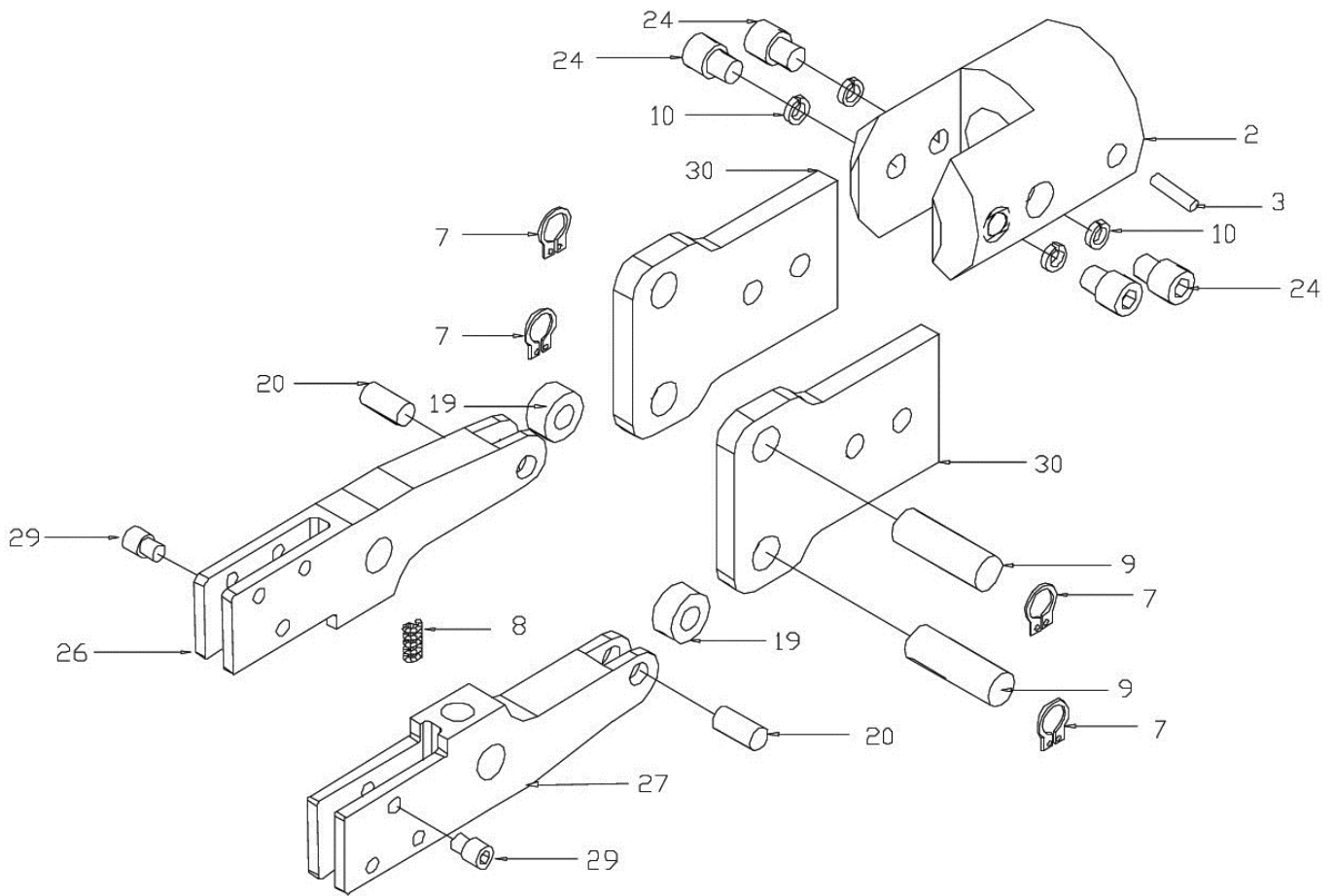

DRWG. NO	DESCRIPTION	PART NUMBER
2	JAW HOUSING FOR A-4 JAWS	4-2B
3	SET SCREW	4-3A
7	SNAP RING (4 required)	4-7A
8	INTERNAL JAW SPRING	4-8A
9	PIVOT PIN (2 required)	4-9A
10	LOCK WASHER (4 required)	4-10A
19	JAW ROLLER (2 required)	4-19-525-K2
20	ROLLER PIN (2 required)	4-20A
24	JAW ASSEMBLY SCREW (4 required)	4-24A
26&27	JAW SET	RUC-9
29	INSERT HOLDING SCREW (2 required)	38-RU-9
30	SIDE PLATE (Set of 2)	4-30A

NOTE: UC-9 REQUIRES THE 25-S CAM ON POWER PACK
PARTS #26 AND #27 ARE NOT SOLD SEPERATELY

ASSEMBLY

- Do not exceed recommended wire size for jaws. Use of other than UC-50-X series of Simonds inserts will void warranty. Crimping inserts are sold separate.
 - Use Teflon tape on hose threads, attach hose to foot switch and to power pack.
 - Extend piston in power pack by pressing on foot pedal (treadle on hand model).
 - Squeeze jaws together, align the jaw set with the wedge (flats) of the piston cam and push housing down on to extended piston until threads meet, twist on until tight.
 - Jaws should be cleaned and foreign material removed weekly, more often if necessary.
 - Prior to use attach air hose to air inlet of power pack using proper wrench size. Check that all threads are free of debris.
 - Attach air hose to Air filter/Regulator using a quick disconnect device. Be sure that air hose is secure. There should be no air leaks. If there is, remove hose and check threads for damage. Reattach air hose, tighten.
- **ISOLATE AIR WHILE ATTACHING HOSE AND JAW HEAD!**
- Test unit to assure free movement of jaws. Be sure to follow all safety instructions when testing.
 - Once unit has been tested and safety issues addressed the unit is ready for production line use.

SIMONDS SQUEEZE PLIERS JAWS ARE FACTORY RESHARPENABLE, PLEASE CONSULT YOUR DISTRIBUTOR.

KEEP FINGERS AWAY FROM MOVING PARTS.
MOVING PARTS MAY CAUSE BODILY HARM!



WARRANTY

Simonds Inc. power packs are warranted to be free from defects in materials and workmanship for a period of one year, barring alterations, abuse or misuse. All products returned for warranty repair must be sent to Simonds Inc., Southbridge, MA at end users expense. Simonds will either repair or replace the tool if it is found defective due to material defect or workmanship at Simonds discretion.

Warranty repairs accepted only through distributors with proper RMA's.

OPERATING INSTRUCTIONS:

- Maximum inlet pressure is 6.895 BAR (100 PSI). The power pack needs to have an inline locking regulator to assure that maximum inlet pressure is not exceeded. Minimum air pressure is 2.758 BAR (40 psi). O-rings may not seat properly and unit can leak air if lower than 2.758 BAR (40 psi).
- For longer tool life it is recommended to use only enough air to complete the job, never exceeding the recommended pressure.
- Tools should have an in line air filter to remove debris, water and particulates. Inline air filter and regulator should be not more than 1.829 meters (6 feet) from the tool.
- An inline lubricator will help to extend the life of the tool. Only use pneumatic oil in the lubricator. If no lubricator is available place a few drops of pneumatic oil in to the air inlet of tool each week. Only lubricants recommended by Simonds are to be used.
- Only tools or jaws recommended and manufactured by Simonds are to be used on this power pack. Use of other tools may constitute a hazard or void warranty.
- Air hose must be securely fastened to the air inlet prior to using. Be sure hose is tightened using the proper tool. The air hose should have a .25 mm (1/8") NPT thread attached that will screw in to the tool end.
- Air hose should be attached to air supply (air filtration system) securely. It is recommended that a quick disconnect device be used to attach air hose to air supply.

SAFETY INSTRUCTIONS

- Inspect tools and hoses each day prior to operation. Air hose that is frayed, cut or abraded should be replaced. Be sure that threads are clean and not worn.
- If the tool is not in use and not positively disconnected from the energy supply, the energy supply system must facilitate isolation and dissipation of pressure by a suitable and lockable shutoff device in order to prevent unexpected start-up.
- Beware of hair, fingers, ties, loose clothing etc. when operating the tool. Keep away from moving parts.
- Always wear eye protection when operating the tool. Beware of ejection of cuttings or chips. Turn head to avoid being exposed to this operation.
- Beware that working on brittle material may cause harmful splinters.
- Always disconnect from air supply when changing tool, during repair, adjusting and inserting tools, maintenance and cleaning operations.
- Simonds tools are not designed for use in explosive atmospheres.
- Simonds tools are not insulated for coming in to contact with electric power sources.
- Do not use tools near personnel where risk of flying debris may hit them.
- Do not point or aim tool at another person.
- Unsecured or cut air hose may cause a whipping action which may result in injury.
- Do not use any attachments not manufactured by Simonds for this tool. Injury may result.
- If the tool is used on a bench stand or a work station be sure that the tool is fastened properly.
- Dispose of tool and material as recommended by local disposal regulations.
- Simonds tools are not for use other than on production line. Tool should not be used as a hammer or pry bar. A "two hand control" may be required depending on the attached tool..
- **DO NOT EXCEED RECOMMENDED WIRE SIZE OR AIR PRESSURE.** Exceeding the recommended wire size for the jaws may cause damage to tool or injury to user.